

B-I-C Speaker Systems are designed to the highest possible value and performance standards. Our confidence in their quality is such that B-I-C America offers customers this seven-year limited warranty:

## B-I-C Speaker Systems U.S.A. Seven-Year Limited Warranty

If the B-I-C speaker system proves to be defective in materials or workmanship within seven years from the date of the original customer's purchase, we will, at our option, repair or replace the defective product.

### DISCLAIMER

THE WARRANTY STATED HEREIN IS IN LIEU OF ALL OTHER WARRANTIES, EXPRESS OR IMPLIED, INCLUDING MERCHANTABILITY AND FITNESS FOR PARTICULAR PURPOSE AND ALL OTHER LIABILITIES AND OBLIGATIONS OF B-I-C AMERICA, ALL OF WHICH ARE EXPRESSLY DISCLAIMED. B-I-C AMERICA HAS NOT MADE AND DOES NOT HEREBY MAKE ANY OTHER REPRESENTATION, WARRANTY OR COVENANT WITH RESPECT TO THE CONDITION, QUALITY, DURABILITY, DESIGN, OPERATION, CAPACITY, FITNESS FOR USE OR SUITABILITY OF THE B-I-C AMERICA SPEAKER SYSTEMS.

### Exclusion of Certain Damages

B-I-C America's liability for any defective product is limited to repair or replacement of the product at our option. B-I-C America shall not be liable for incidental or consequential damages of any kind or character because of product defects.

Some states do not allow limitations on implied warranties and/or do not allow the exclusion or limitation of incidental or consequential damages, so the above limitations and exclusions may not apply.

### This Warranty Does Not Cover:

Damage caused by abuse, accident, misuse, negligence, or improper operation.

Products that have been altered or modified.

Any product whose serial number has been altered, defaced, or removed.

Normal wear and maintenance.

Damages caused by shipping. (All claims for shipping damage must be made with the carrier.)

### Warranty Service

Warranty service must be performed by an authorized service center, usually a B-I-C America speaker systems dealer or its authorized agent. You may obtain a list of authorized service centers by calling the number below.

**All warranty repairs must be accompanied by the original bill of sales. No other document is acceptable or is required.**

This warranty gives you specific legal rights, and you may also have other rights which vary from state to state.

Due to our continual efforts to improve product quality as new technology and techniques become available, B-I-C America reserves the right to revise Speaker Systems specifications without notice.

# Owner's Manual



## DV52CLR Center Channel



## DV62CLR-S Center Channel

### SPECIFICATIONS

|                                   | DV52CLR                         | DV62CLR-S                  |
|-----------------------------------|---------------------------------|----------------------------|
| <b>Frequency Response</b>         | 80 Hz-20kHz                     | 38 Hz-20kHz                |
| <b>Characteristic Sensitivity</b> | 90dB @ 1 watt, 1 meter          | 90dB @ 1 watt, 1 meter     |
| <b>Nominal Impedance</b>          | 8 ohms                          | 8 ohms                     |
| <b>Crossover Frequency</b>        | 5000 Hz                         | 3500 Hz                    |
| <b>Undistorted Amp Power</b>      | 10 - 125 watts                  | 10 - 175 watts             |
| <b>Dimensions</b>                 | 6 1/2" H x 17 1/2" W x 6 1/2" D | 7 11/16" H x 20" W x 10" D |
| <b>Shipping Weight</b>            | 14 lbs.                         | 19 lbs.                    |



### B-I-C America

925 N. Shepard Street  
Anaheim, CA 92806  
www.bicamerica.com

For tech support call 1-877-558-4242 (4BIC)



## Unpacking

Carefully remove your new B·I·C center speaker from the box, avoiding staples which can cause damage to the cabinet. Inspect the speaker for transit damage. If you discover damage, contact your dealer immediately.

Save your carton – it is the best possible protection for your speaker should you ever have a need to move it.

## Speaker Setup(s)

Figure 1 below shows 5.1 and 6.1 speaker placement. Front center-channel speakers should be placed as close to

the TV as possible, preferably directly above or below the set. The front channel speakers should be placed at least 6 feet apart (TV/monitor center) to create proper stereo imaging. The 5.1 surround speakers should be placed to the side of listeners. The rear-center speaker should be positioned directly behind the listening area. Rear channel speakers for 7.1 systems should be positioned behind and slightly to the sides of the viewer/listener. It may take some experimentation with different locations for the surround speakers to suit your preference and your room.

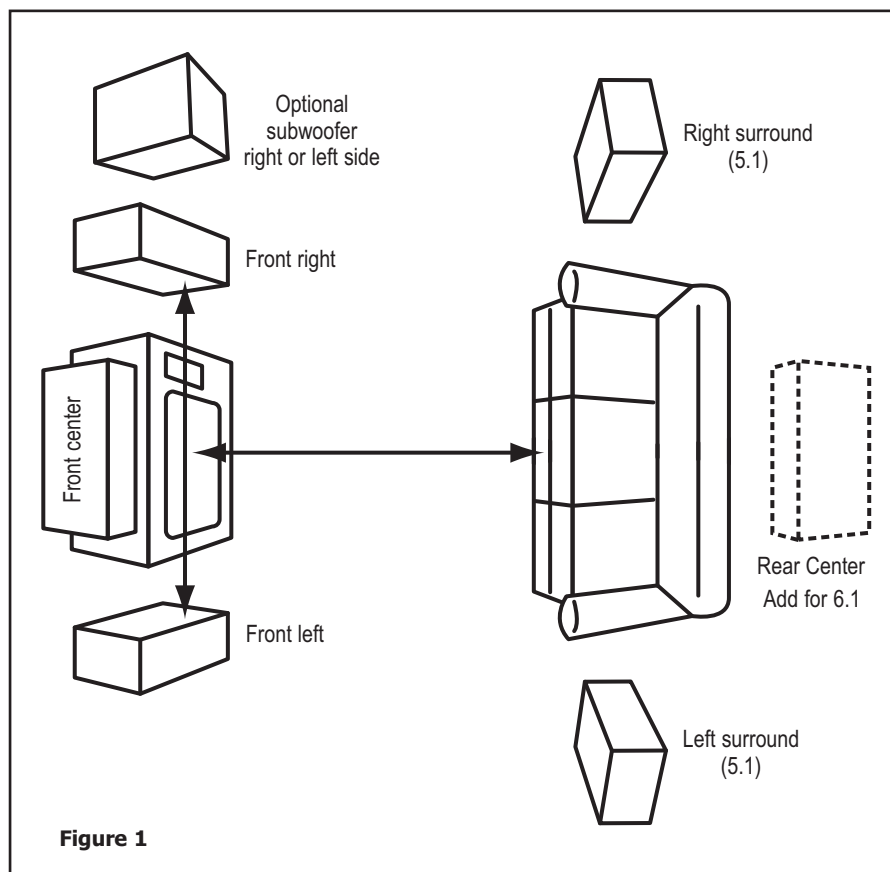

Figure 1

## Hooking Up Your New Speakers

**STOP!** – Make sure that you consult your amplifier's owner's manual regarding speaker hook-up. Your amplifier should be turned off throughout this procedure.

A word about speaker wire – There are a number of quality speaker wire products available today. Most of these products offer obvious cosmetic benefits over lamp cord and light gauge wires. The DV62si speakers come equipped with inputs that allow the greatest flexibility and choice of hook-up wire and connectors. The choice of speaker wire is dependent on the type of amplifier, the distance you intend to run the wire, and your budget, among other things. If in doubt as to which brand or type of wire and connector to use, consult your audio dealer.

Most speaker wire is polarity coded. This means that each conductor is labeled either (+) positive or (-) negative. The (+) positive side may be a different color or texture than the (-) negative side. On the back of your amplifier, each channel is probably labeled (+) and (-) as well as color coded red for (+) positive and black for (-) negative. B·I·C speaker terminals are color coded red for (+) positive and black for (-) negative. Be sure to hook (+) to (+), (red to red), and (-) to (-), (black to black). (See Figure 2.)

All connections should be tight and close fitting. Inspect connections for frays and stray strands of wire touching both (+) and (-) terminals. (This will cause a short and, perhaps, damage your equipment.)

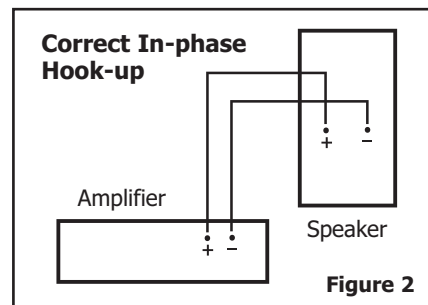

Figure 2

## Caring for Your Speakers

B·I·C speaker cabinets are finished with a very high quality laminate covering that is both attractive and serves as excellent protection for the wood cabinet. The cabinet can be cleaned with a damp, soft cloth or you may use a high-quality furniture polish to maintain the original luster. Use a soft brush or hand vacuum cleaner on the grille material.

## Troubleshooting and Service

B·I·C speakers do not use external fuse protection or circuit breakers because these devices tend to impede sound quality and may only protect the speaker to a marginal degree. Rather, we use components and designs of the highest caliber as an effective method of protecting the speaker. However, no amount of protection will prevent damage caused by defective associated equipment or extreme abuse.

If your speaker has no output, first try to determine if it is indeed a speaker problem. Determine whether the problem exists in both speakers. If it does, the problem likely originates in some other component in the system. If the problem is in one speaker only, reverse your speaker leads (left to right, right to left). If the problem moves to the other channel, the issue is not the speakers.

If you have determined that your speaker is not functioning properly, or you have questions, please contact B·I·C America at 877-558-4242.

## B·I·C America

925 N. Shepard Street  
Anaheim, CA 92806

[www.bicamerica.com](http://www.bicamerica.com)

For tech support call 1-877-558-4242.

Please describe the problem in detail. We will decide on the most appropriate course of action.