

B-I-C Venturi Speaker Systems are designed to the highest possible value and performance standards. Our confidence in their quality is such that B-I-C Venturi offers customers this transferable limited warranty:

B-I-C Venturi Speaker Systems Limited Warranty

If the B-I-C Venturi speaker system proves to be defective in materials or workmanship within seven years from the date of the original customer's purchase, we will, at our option, repair or replace the defective product.

DISCLAIMER

THE WARRANTY STATED HEREIN IS IN LIEU OF ALL OTHER WARRANTIES, EXPRESS OR IMPLIED, INCLUDING MERCHANTABILITY AND FITNESS FOR PARTICULAR PURPOSE AND ALL OTHER LIABILITIES AND OBLIGATIONS OF B-I-C VENTURI, ALL OF WHICH ARE EXPRESSLY DISCLAIMED. B-I-C VENTURI HAS NOT MADE AND DOES NOT HEREBY MAKE ANY OTHER REPRESENTATION, WARRANTY OR COVENANT WITH RESPECT TO THE CONDITION, QUALITY, DURABILITY, DESIGN, OPERATION, CAPACITY, FITNESS FOR USE OR SUITABILITY OF THE B-I-C VENTURI SPEAKER SYSTEMS.

Limitation of Implied Warranties

Any implied warranties, including warranties of merchantability and fitness for a particular purpose, are limited in duration to the length of this warranty.

Exclusion of Certain Damages

B-I-C Venturi's liability for any defective product is limited to repair or replacement of the product at our option. B-I-C Venturi shall not be liable for incidental or consequential damages of any kind or character because of product defects.

Some states do not allow limitations on implied warranties and/or do not allow the exclusion or limitation of incidental or consequential damages, so the above limitations and exclusions may not apply.

This Warranty Does Not Cover:

Damage caused by abuse, accident, misuse, negligence, or improper operation.

Products that have been altered or modified.

Any product whose serial number has been altered, defaced, or removed.

Normal wear and maintenance.

Damages caused by shipping. (All claims for shipping damage must be made with the carrier.)

Warranty Service

Warranty service must be authorized or performed by a B-I-C authorized service center.

All warranty repairs must be accompanied by the original bill of sale and a B.I.C warranty claim form. No other documents are acceptable or required.

This warranty gives you specific legal rights, and you may also have other rights which vary from state to state.

Due to our continual efforts to improve product quality as new technology and techniques become available, B-I-C America reserves the right to revise Speaker Systems specifications without notice.

Owner's Manual



Model DV84 Model DV64
Stereo / Home Theater Speaker Systems



Specifications

Model	Freq. Resp.	Characteristic Sensitivity	Driver Complement	Crossover Freq.	Nominal Impedance	Undistorted Amp. Power	Dims.	Shipping Weight
DV84	27 Hz - 22kHz	90 dB @ 1 watt, 1 meter	1 - 3/4" tweeter 2 - 8" woofers 2 - 8" passive radiators	3000 Hz	8 ohms	10 - 250 watts	43 1/2" H 10" W 11 3/4" D	47 lbs. each
DV64	29 Hz - 21kHz	90 dB @ 1 watt, 1 meter	1 - 3/4" tweeter 2 - 6 1/2" woofers 2 - 6 1/2" passive radiators	3000 Hz	8 ohms	10 - 200 watts	38" H 8 1/2" W 9 1/4" D	35 lbs. each



B-I-C America

15335 Don Julian Road
City of Industry, CA 91745

www.bicamerica.com

For tech support call 1-877-558-4242 (4BIC)

B-I-C America is a licensed trademark

Speaker Systems by **B-I-C America**
Top rated since 1973

Unpacking

Carefully remove your new Venturi speakers from their boxes, avoiding staples which can cause damage to the cabinets. Inspect each speaker for transit damage. If you discover damage, contact your dealer immediately. Save your cartons – they are the best possible protection for your speakers should you ever have a need to move them.

Positioning Your Speakers

The room that you choose to use as your Home Theater will add its own "sonic signature" to the sound of your system. In selecting a room and speaker position, it is important to remember the effect of furnishings, materials, and surfaces, and how room dimensions affect your speakers' performance. Experimentation in speaker placement is necessary to choose the best arrangement for your optimum experience. Your B·I·C Venturi dealer may prove helpful in establishing a starting point by which to discover optimum placement. However, here are a few general rules to get you started.

Choice of room – if you have a choice as to which room in your home to use as the listening room, here are some things to look for:

- Rooms with varying wall lengths, non-parallel walls, uneven ceilings, and generally varying dimensions will usually produce a more even sound and offer a greater variety of choices for speaker placement.
- An even mixture of hard and soft surfaces will typically help neutralize the sound of the room. Soft surfaces such as stuffed furniture, heavy curtains, and carpet absorb higher frequencies while hard surfaces such as glass and hardwood floors tend to cause greater reverberation at the higher octaves.
- Solid wall construction and concrete floors provide the best vibration-free foundation for your system.

IMPORTANT HINT: Adjustments to the sound of your room can often be made very simply. Hanging pictures on a wall to create an uneven surface, drawing the drapes one way or the other, or moving a piece of furniture can often create the desired effect. Remember to experiment!

The Optimum Listening Position

Home Theater and music are great joys of life, particularly when enjoyed in the comfort of

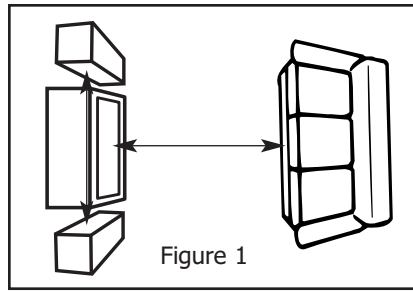

Figure 1

Note: The distance between yourself and the point directly between the speakers is slightly (roughly 20%) greater than the distance between the two speakers.

your own home. When choosing the location of your speakers, remember to base your decision around your favorite chair or most comfortable listening position. (See Figure 1.)

The Distance Between Each Speaker

This part will require some experimentation and is somewhat dependent on the size of the listening area. However, as a general rule, the best results are usually attained when the speakers are 6 feet apart centered on your TV. In larger rooms, greater distance between the speakers is possible but may require angling in of the speakers for the maximum effect.

Distance Between the Speakers, the Rear Wall, and Side Wall

We have achieved optimum results throughout design phases, listening tests, and evaluation with the speaker 2 to 3 feet out from the rear wall (see Figure 2). Moving the speaker closer to the rear wall or a room corner will tend to "color" or enhance the lower frequencies. Placing the speaker closer to the rear wall will also tend to adversely affect the depth of the stereo image.

Hooking Up Your New Speakers

STOP! — Make sure that you consult your amplifier's owner's manual regarding speaker hook-up. Your amplifier should be turned off throughout this procedure.

A word about speaker wire – There are a number of quality speaker wire products available today. Most of these products offer obvious cosmetic benefits over lamp cord and light gauge wires. B·I·C Venturi Speaker Systems come equipped with gold-plated binding posts.

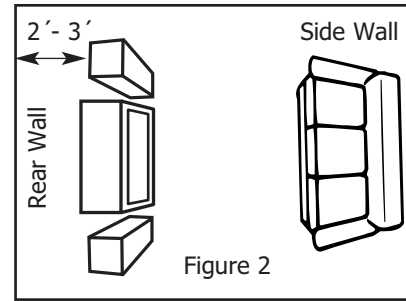

Figure 2

Note: For best results, maintain a maximum distance away from the side wall consistent with speaker separation.

The choice of speaker wire is dependent on the type of amplifier, the distance you intend to run the wire, and your budget, among other things. If in doubt as to which brand or type of wire to use, consult your audio dealer.

Most speaker wire is polarity coded. This means that each conductor is labeled either

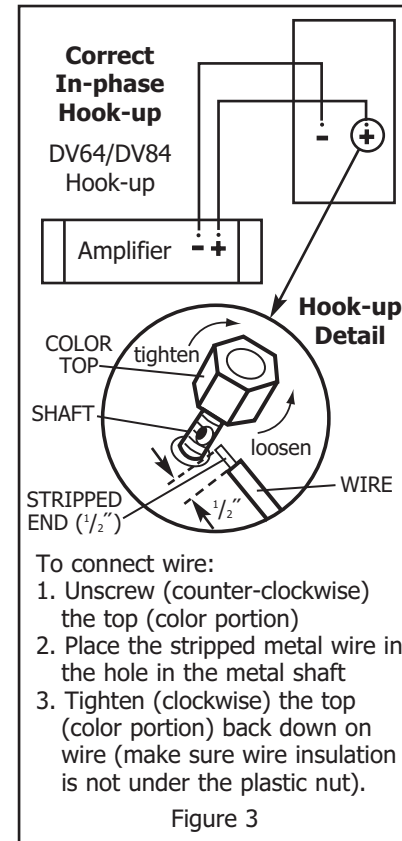

Figure 3

(+) positive or (-) negative. The (+) positive side may be a different color or texture than the (-) negative side. On the back of your amplifier, each channel is probably labeled (+) and (-) as well as color coded red for (+) positive and black for (-) negative. B·I·C Venturi speaker terminals are color coded red for (+) positive and black for (-) negative. Be sure to hook (+) to (+), (red to red), and (-) to (-), (black to black). (See Figure 3.) All connections should be tight and close fitting. Inspect connections for frays and stray strands of wire touching both (+) and (-) terminals. (This will cause a short and, perhaps, damage your equipment.)

Caring for Your Speakers

B·I·C Venturi speaker cabinets are finished with a very high quality wood grain laminate covering that is both attractive and serves as excellent protection for the wood cabinet. The cabinet can be cleaned with a damp, soft cloth or you may use a high-quality furniture polish to maintain the original luster. Use a soft brush or hand vacuum cleaner on the grille material.

Troubleshooting and Service

B·I·C Venturi speakers do not use external fuse protection or circuit breakers because these devices tend to impede sound quality and may only protect the speaker to a marginal degree. Rather, we use components and designs of the highest caliber as an effective method of protecting the speaker. However, no amount of protection will prevent damage caused by defective associated equipment or extreme abuse.

If your speaker has no output, first try to determine if it is indeed a speaker problem. Determine whether the problem exists in both speakers. If it does, the problem likely originates in some other component in the system. If the problem is in one speaker only, reverse your speaker leads (left to right, right to left). If the problem moves to the other channel, the issue is not the speakers.

If you have determined that your speaker is not functioning properly, or you have questions, please contact B·I·C America at 877-558-4242.

B·I·C AMERICA
Top rated since 1973

15335 Don Julian Road
City of Industry, CA 91745
www.bicamerica.com