

Acoustech

Installation and Owner's Manual



Model H-310C Ceiling Speaker

Speaker Systems by **B·I·C** America™

TABLE OF CONTENTS

A	What you need to do the job	
	Speaker parts inventory	2
	Tools for installation	2
	Speaker wire.....	3
	Amplifier considerations.....	3
B	Where to put your speaker(s)	
	Various uses.....	3
	Background music.....	3
	Surround sound.....	3
	Other acoustic considerations	3
	Wall & ceiling surfaces	4
	Speaker wire paths	4
C	Cloth décor & paintable grille(s)	4
D	Cutting holes for the speaker(s)	4
E	Running connecting wire(s)	5
F	Hooking up your speaker(s)	
	At the speaker end.....	6
	At the amplifier end	6
G	Final assembly.....	6
H	A short “test drive”	6
	A quick troubleshooting guide.....	7
	Further reading	
	Taking care of your new in-ceiling speaker	7
	More on amplifiers and impedances.....	7
	Installing B-I-C speakers during new construction.....	7
	B-I-C H-310C description and specifications.....	8
	Limited Warranty.....	8

CONGRATULATIONS

— on selecting this B-I-C Ceiling Speaker. Like all B-I-C speakers, the H-310C combines advanced acoustic technology with durability and will provide years of musical enjoyment.

This manual is designed to make your ceiling speaker as easy to install as it is to listen to. If you've had any home “do-it-yourself” experience, you should find installation of your new speaker a simple job.

However, we suggest you read through this manual before starting out. If you then decide that installing your B-I-C Ceiling Speaker is a bit beyond your skills, we've included suggestions for locating sources of affordable outside help.

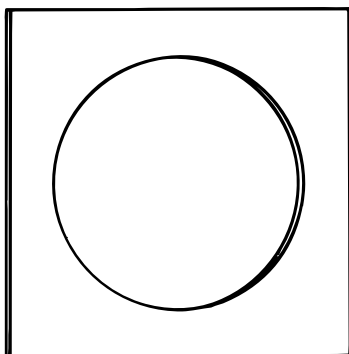

Cutout & Masking Template



Speaker



Black grille adhesive in poly bag

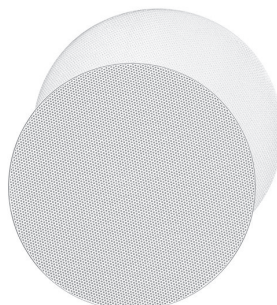

2 Grilles

DRAWING 1



WHAT YOU NEED TO DO THE JOB

SPEAKER SYSTEM PARTS INVENTORY

Before you get involved in the actual installation process, it's a good idea to check for possible shipping damage and identify parts and hardware.

You should have the parts shown in Drawing 1:

- One B-I-C loudspeaker with one cloth décor and one metal grille
- White cardboard template: includes one cutout template & one masking template for painting
- Black grille adhesive

If anything is missing after a thorough search of the box and packing materials, contact the dealer where you bought your speaker.

Although B-I-C Speakers are extremely well packed to withstand the rigors of shipping, you should still inspect them closely, especially if there is any damage to the outside carton. If you find anything wrong, contact your dealer or the shipper who delivered the speaker.

TOOLS FOR INSTALLATION IN EXISTING WALLS

It doesn't take a whole workshop to install your new speaker, just a few simple tools:

- A pencil
- A drill with a 1-inch flat bit
- A retractable utility knife or keyhole saw
- A length of stiff wire about 3 feet long (a straightened wire coat hanger works fine)
- A Phillips-head screw driver
- A pair of diagonal pliers or wire strippers

Some of the following may also be needed, depending on the application.

- A stud finder
- Drill bit just slightly larger than the diameter of one speaker wire
- Plumb bob or small weight on a string
- Insulated staples for securing speaker wire
- Masking tape or foam “double-stick” tape
- Paint and applicator for changing grille and outer frame finish

SPEAKER WIRE

The amount of wire you're going to need will vary with speaker placement (which we cover next). But we're covering the subject of wire now because it's something you may have to go out and obtain along with whatever tools you don't already have.

What kind to use

We recommend using inexpensive, multi-stranded "zip-cord" for amplifier-to-speaker connections. Also called lamp cord, it's sold in pre-packed rolls and in bulk displays at hardware, lighting and home improvement stores. Zip-cord's outside covering (insulation) can be transparent, black, brown, white, etc. Color doesn't matter. Wire-thickness does. For in-wall and in-ceiling, a good quality wire should be used so the outside plastic covering won't crack and break down over time.

Selecting the proper gauge

Wire is measured in "gauges." For no particularly good reason, the bigger the number, the smaller the wire. For example, 18-gauge is thinner than 14-gauge.

The gauge of wire you need is determined by the distance between your amplifier/receiver and the speakers. Use the following chart as a guide:

Length	Minimum Gauge
Less than 10 ft.	18
10 to 50 ft.	16
Over 50 ft.	14

If in doubt, be safe and get a smaller gauge (i.e. thicker wire). Using too thin a gauge over a long distance can compromise sound quality. And besides, there isn't a vast cost difference between gauges.

How much to buy

Basically, more than you think you need. As we noted earlier, a discussion of lengths is sort of premature until you've decided on exact placement, so you may want to skip to Section B on "Where to put your speakers." But if you have a rough idea of the distance from your amplifier to the speakers, here are a few tips:

- Because of the complicated paths which are often required to route wires, you'll definitely need more than the amount derived from simple measurements.
- Even if one speaker is a lot closer to the amp than the other speaker, you should use the same length of wire for both paths. This ensures that both speakers will play at equal volume.
- Professional installers often use the following rule of thumb: amp to speaker distance **TIMES FIVE**. That allows enough for both speaker paths plus a very healthy margin for unplanned detours. Remember the electrician's favorite adage:
"You can always cut off extra wire, but you cannot make wire longer once it is cut."

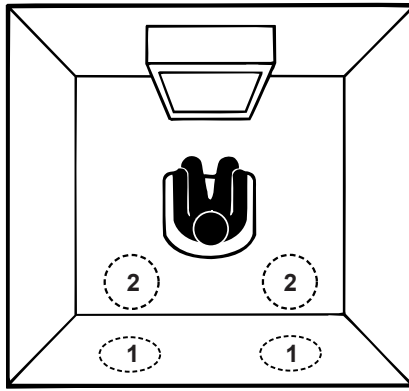

B-I-C ceiling speakers may be used for surround and rear sound channels by placing them (1) behind or (2) in the ceiling, just behind the viewer.

DRAWING 2

AMPLIFIER CONSIDERATIONS

Virtually any receiver, power amplifier or integrated amplifier can be used with your B-I-C Ceiling Speaker. Although B-I-C speakers are rated for high power, it's OK to use an even more powerful amplifier if you take some simple precautions, which we cover on page 7 ("Taking care of your new B-I-C speakers").

A more serious consideration is whether or not you intend to power more than one set of speakers with the same amplifier or receiver. If you intend to hook speakers to both "A" and "B" receiver outputs and then play both sets of speakers at the same time, you should read the section starting on page 7 of this manual ("More on amplifiers and impedances"), to avoid potential problems.



WHERE TO PUT YOUR SPEAKER(S)

Since these are primarily used in ceiling applications, we highly recommend installing in an open attic space. If you need to go into the ceiling of a first floor room (in a two story house), we recommend the use of a professional installer.

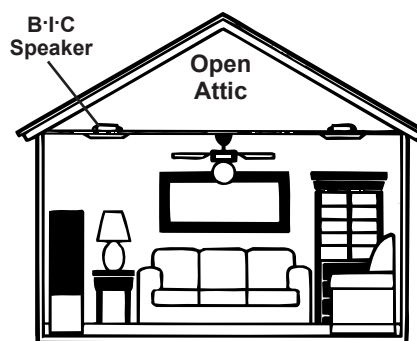

Standard Room

DRAWING 3

Placement can make all the difference in how your B-I-C speaker systems sound – and how easy they are to install. There are at least three "WHERE'S" and a "HOW" to factor into your layout:

- **HOW** you intend to use your speakers
- **WHERE** they'll sound best (acoustic considerations)
- **WHERE** it's possible to install them (ceiling surfaces)
- **WHERE** they can be installed that makes it easy to get wire to them without remodeling your entire house.

VARIOUS USES

B-I-C Ceiling Speakers can be used for background music, as a primary listening system, or as built-in surround and rear speakers in an audio/video home theater.



Background music

If you just want low-volume background music to float through a room, placement for best acoustics is not particularly critical. You can pretty well ignore all our diagrams and tips on imaging and other acoustical matters. Just put your speaker where it's convenient and non-intrusive to room decor. You can even place the speaker in an adjoining room, such as a living room that flows into a formal dining room, or in a kitchen and breakfast nook.

Surround sound

B-I-C Ceiling Speakers make excellent surround and rear speakers. They can be mounted in any of the positions shown in Drawings 2 and 3, especially from the ceiling.

OTHER ACOUSTIC CONSIDERATIONS

For best fidelity, there are several other factors to keep in mind before you start actual installation.

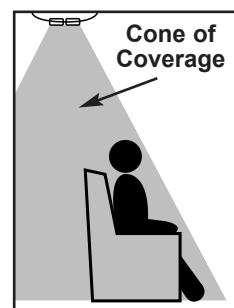

DRAWING 4

Vertical placement

Treble frequencies are quite directional. While the dome tweeters in B-I-C H-310C speakers are designed to disperse high frequencies over a wide area, they will give you the best sound when positioned so that they cover the listening area in a cone of

coverage as shown in Drawing 4. Of course, if the speakers are being installed in an area where listeners usually stand up (such as a kitchen or hallway), they are best suited for ceiling mount (see Drawing 3).

Corners and reflections

When a speaker is placed close to the corner of a room, bass frequencies are emphasized.

Treble is emphasized when it reflects back from reflective surfaces such as large windows. Conversely, highs tend to be muffled by soft surfaces such as drapes, rugs, upholstered furniture, carpeted steps and even textured fabric wall paper.

WALL AND CEILING SURFACES

Now that we've covered where you should put your speakers, let's consider where you CAN put them.

B-I-C H-310C speakers require at least 5 1/4" of depth (measured from the outside surface of the wall). This means that they can be installed in any space wide and deep enough for them, including most ceilings. Ceiling plasterboard (or lath and plaster in older homes) acts as a superb speaker baffle.

Because the depth of H-310C ceiling speakers is deeper than typical 2" x 4" wall studs, H-310C cannot be installed in most walls.

Avoid:

- Ceilings covered only with thin veneer paneling – the surface isn't rigid enough and can cause annoying vibrations and buzzing.
- T-bar "drop ceilings" with very thin fiberboard panels which can buzz and vibrate. If you suspect this will happen, reinforce the drop-in panel with wood or particle board.
- Any mounting area which can't provide proper depth (clearance) for the back of the H-310C speakers to protrude. This includes brick or concrete walls where the wallboard or paneling is attached to thin furring strips.
- Ceilings where you know that there are pipes, heating ducts and ESPECIALLY AC wiring in the general vicinity.

4

SPEAKER WIRE PATHS

The last consideration is the obstacle course that lies between the speakers' hoped-for mounting positions and your stereo system.

Wire can be run through crawl spaces that lie above your ceiling or below the floor, through basements of second stories, or simply along the perimeter of your listening room. We cover each of these options in detail in the "Running connecting wires" section of this manual.

In general, you should pay particular attention to the following areas:

- Avoid running speaker wires close to house electrical wiring for any distance. If you have to run them parallel, make sure to space the speaker wires at least two feet from the AC line. It is, however, OK for speaker wires to cross paths with AC line or go through the same hole together with house wiring if they separate before and after.
- Make sure that the entire path between speakers and amplifier is clear and not obstructed by a major floor or ceiling joist or masonry wall which you won't be able to drill through.
- Remember that the other end of the wires has to come out somewhere to connect with the amplifier. Confirm ahead of time that you can drill an outlet hole easily and in an unobtrusive spot.



CLOTH DÉCOR & PAINTABLE GRILLE(S)

If you like the designer white finish, we recommend you use the white cloth décor accessory grille included with your new H-310C speaker. But if you want your speaker to completely blend in with a colored wall or accent the surface, a paintable metal grille is also included with your new H-310C speaker.

The speaker's outer surface is primed to accept ordinary latex wall paint or aerosol spray paint. Because the surface behind the perforated grille will remain the same, you will need to mask this area off before you begin painting.

1. First the speaker's grille must be removed.

From the back of the speaker, use the mounting legs to push the grille off.

2. If you are going to use standard, canned, wall paint so your speakers will match the wall color, you will need to thin the paint to nearly the consistency of water. This is critical since paint with any thickness will plug the holes in the grille which will impede the sound from getting to the room. Once you thin the paint it may take several coats to get good consistent color coverage without plugging the holes in the grille. One trick to use is to blow air through the grille holes as you are in the painting process to keep the holes open. Paint the outer speaker frame and grille separately. A medium nap roller or fine brush will work OK if you take your time and are careful. If you're using spray paint, make sure that you achieve the same coverage on both grille and frame. Take care to use very light coats on the grille to avoid plugging the holes (perforations). Also, be sure to spray at different angles to achieve good even coverage

of the perforations and edges. You must take extreme precautions when painting the grille not to get paint in the holes of the grille. There's no need to replace the grille at this time since you will need access to the inner speaker surface during installation.



CUTTING HOLES FOR THE SPEAKER(S)

Wallboard is an easy surface in which to make a relatively neat hole. Actually, the hole doesn't even have to be that neat, since the speaker's outer frame will cover it. Just make sure you don't make it any bigger than the template. In the following steps, you're going to locate a section of ceiling between the wood framing or in the wall between two studs, mark the outer boundaries of the hole, drill a small hole in the center to confirm your location and then cut the main hole.

1. First you must determine the location of your ceiling supports so that the speaker can be approximately centered between them. There are several ways to go about this:
 - Tap on the surface and listen to the resulting "THUMP". When it's deeper, you're between studs. When it's sharper and more flat-sounding, you're close to a stud.
 - Use a stud-finder, a simple little device which works by locating the studs behind a ceiling.

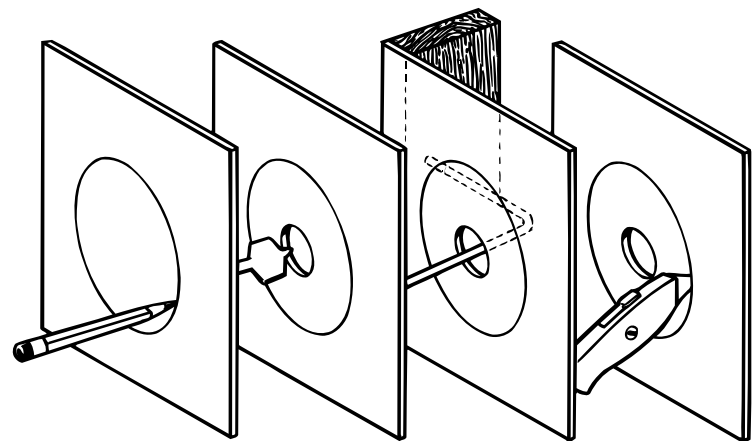

A. Trace template outline

B. Drill 1 inch pilot hole

C. Probe with wire for stud clearance

D. Cut speaker hole along outline

DRAWING 5

2. When you're reasonably sure of where the ceiling joist (studs or framing) are (and are **TOTALLY** sure that there isn't an electrical cable, water pipe or heating duct in that vicinity of your proposed cutout) position one of the cardboard mounting templates and draw around the inside outline with a pencil.
3. Drill a 1-inch hole in the center of the pencil outline which you have just drawn.
4. Obtain a length of stiff wire such as an unwound, totally un-bent coat hanger. Bend it so that the last 12 inches is at a right angle to the rest.
5. Insert the angled part into the 1-inch hole you just drilled and probe to left and right to confirm that a stud is not close on either side.
 - If there is a close stud on one side, just reposition the cardboard template a few inches in the opposite direction and re-draw your pencil outline, keeping the 1-inch hole within the pencil outline's inner boundaries.
6. If there are no obstructions, cut the hole along the pencil outline. If the surface is wallboard, simply cut it increasingly deeper with utility knife until it gives way and then pull it out by grasping the cut-out through the 1-inch hole.
 - If you're dealing with lath and plaster or thick paneling, you need to use a different technique. Drill 1-inch holes at opposite sides of the pencil outline. Then use a keyhole saw or even a hacksaw blade with **VERY** slow strokes to saw through and remove the inner surface.
7. Temporarily place the B-I-C speaker into the cut-out to insure that it fits properly. It's OK if the hole is slightly large, since it will be covered by the speaker's outside frame. Actual installation will happen later, after you've routed the speaker wires.
8. Repeat if installing more than one speaker.
9. Now it's time to drill the hole on the **OTHER** end – at the point where the wires from the speakers will exit to the amplifier/receiver.
 - Use the same 1-inch drill bit as before.
 - If you want a totally finished job, install an outlet box against a stud and cover it with a TV cable or single outlet plate which has one hole in the middle for the wires to exit from.



RUNNING CONNECTING WIRE(S)

Now you know where the wire(s) have to run. It's time to actually route them.

If you have an attic or overhead crawl space, your two steps are:

- 1) Route wire(s) up from the amplifier to the crawl space;
- 2) Route wire(s) across the crawl space to the speaker(s).

ROUTING WIRE UP TO SPEAKER (ATTIC CRAWL SPACE)

See Drawing 6

1. You're about to ascend into your attic. Grab the following:
 - Tape measure
 - Cordless drill with a 1-INCH BIT (or non-cordless model with long extension cord)
 - A **VERY** long roll of speaker wire
 - Wire cutters – either diagonal pliers or wire strippers which include a cutting surface.
 - Plumb bob or string with a small weight (such as a metal nut) on the end
 - Tape – any kind will do
2. Crawl up into the attic with all the aforementioned stuff and proceed to a spot that's directly over a speaker cut-out hole.
3. Time to use that roll of cable. Push a cable through the speaker cut-out.
4. Making sure the end doesn't get pulled back up through the hole, reel out cable while moving across the attic/crawl space until you reach the location above your amplifier.
5. Extend at least 10 (**TEN**) more feet of cable for the roll and cut it.
6. You now have a cable running from the speaker. Repeat steps above if installing more than one speaker. Time to get them down the wall to where the amplifier will be.
7. Drill a 1-inch hole through the horizontal 2 x 4 directly above the amplifier wall outlet.

8. Now you're going to guide cables down to where they'll emerge from the wall. Since this hole isn't very big, just stuffing them down and grabbing them won't work. Instead, it's time for the plumb bob or string-with-weight (or wire if there's insulation to contend with). Tape the two cable ends (which come from the speakers) to the plumb bob string just above the weight and lower the whole thing down through the 1-inch hole above the amplifier. You'll probably have to "feed out" the attached cable to get the weight to descend.
9. Continue "feeding out" both cables until they and the weight hit bottom. Tie the free end of the plumb bob string to something so that it doesn't fall down the hole.
10. Exit the attic crawl space.
11. Go over to the 1-inch amplifier wire hole and look for the extended string/plumb bob and attached cables. If they're not visible, form a small hook on the end of your stiff wire/coat hanger, fish around for them, and pull them through the hole. Then rescue the plumb bob from the attic.
12. At the speaker holes, things are much easier. You can just reach through and grab the cables. Pull their whole free length out the cut speaker holes. You've done it!



HOOKING UP YOUR SPEAKER(S)

The main thing to remember when hooking up a speaker is that two conductors in the speaker wire are not interchangeable. One will be used as a **POSITIVE (+)** conductor and the other as a **NEGATIVE (-)** conductor. These correspond to the **RED (+)** and **BLACK (-)** connectors on your B-I-C Ceiling Speaker and also to the speaker terminals on your amplifier or receiver.

IDENTIFYING “+” and “-”

Your need to be able to discriminate between the two conductors in the zip cord.

If your wire has transparent insulation, this is easy: One conductor will be copper-colored and the other silver-colored. Generally, professionals denote the copper one as **POSITIVE (+)** and the silver one as **NEGATIVE (-)**.

If you've used wire which has an opaque insulation, there are still differentiating markings. Examine the wire closely and look for:

- A series of ribs or grooves on one conductor
 - A painted stripe
 - A single strand of yarn intertwined with the multi-stranded wire in one conductor.
- Denote any of these as the **POSITIVE (+)** conductor for similar connections on both ends.

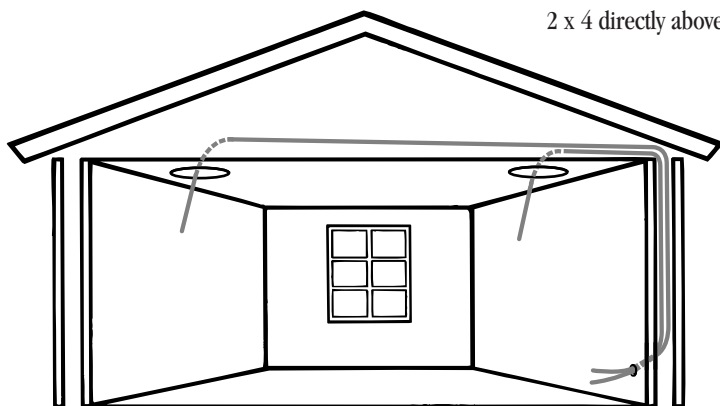

DRAWING 6

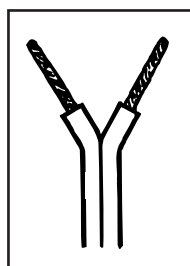

DRAWING 7

AT THE SPEAKER END

1. Cut off excess wire, leaving about 2 feet extending through the speaker cut-out hole.
2. Pull the conductors apart so they're separated for the first two inches from their ends.
3. Using wire strippers, diagonal pliers or a knife, remove 1/2 inch of insulation from each conductor.
4. Twist the tiny strands in each conductor into tight spirals, as shown in Drawing 7.
5. **IMPORTANT:** Route the speaker wire **THROUGH** the hole in the ceiling (Drawing 8).
6. Attach the speaker wires to the red and black speaker terminals. Press down on the protruding levers while inserting the wire into the hole (Drawing 8).

6

- Connect the **POSITIVE (+)** conductor to the **RED** terminal and the **NEGATIVE (-)** conductor to the **BLACK** speaker terminal.
- Make sure that no stray strands of wire have gotten detached and are touching the other main wire.

AT THE AMPLIFIER END

1. Cut off excess wire, leaving enough to comfortably reach from the hole in the wall to your stereo system. If there's a possibility that you're going to move the amplifier to another part of the room, consider leaving some excess wire coiled up. If you've used sufficiently thick wire, this extra length will not affect speaker performance and could make things easier if the room is rearranged later.
2. Pull the conductors on speaker wire(s) apart so they're separated for the first two inches.
3. Using wire strippers, diagonal pliers or a knife, remove 1/2 inch of insulation from each conductor.
4. Twist the tiny strands in each conductor into tight spirals.
5. Attach the speaker wire(s) to the red and black speaker terminals on the amplifier or receiver.
 - Connect the **POSITIVE (+)** conductor to the **RED** terminal and the **NEGATIVE (-)** conductor to the **BLACK** speaker terminal.
 - Make sure that no stray strands of wire have gotten detached and are touching the other main wire.

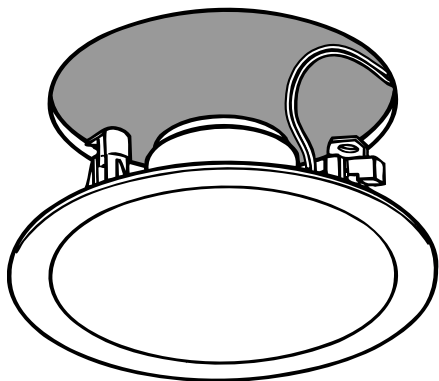

DRAWING 8



FINAL ASSEMBLY

1. If you haven't done so already during painting, remove the perforated grilles from your B-I-C Ceiling Speaker. To remove the grille, just use the mounting screw (dog leg) on the rear to push the grille off.
2. See Drawing 9. Make sure all the clamping brackets (dog legs) are turned inward as shown in the picture before going up on the ladder to install the unit in the ceiling.
3. Find the wire you ran previously (hopefully hanging down through the hole you cut). Strip the ends if you haven't already done so and connect as described in Section F.
4. Insert the speaker into the cutout hole and be certain the wire is not hanging down on the woofer cone.
5. Using a Phillips screwdriver (or powered screwdriver, recommended), start tightening the six screws. As you start the tightening each of the mounting brackets (dog legs) will swing around and follow the screw down to the back of the wall and clamp the speaker into place. Avoid excessive force when tightening the screws to prevent deforming the drywall or breaking the plastic clamp of the speaker. Be sure to go around all six screws and check for even tightness in the clamping pressure.
6. Now is the time to aim the midrange unit and tweeter (if needed) toward your primary listening area. Gently push on the rims so the centers are aiming toward the area you want (See Drawing 10).
7. Replace the grille by gently pressing it into place. Use the supplied black grille adhesive around the edge of the grille when pressing it into place.

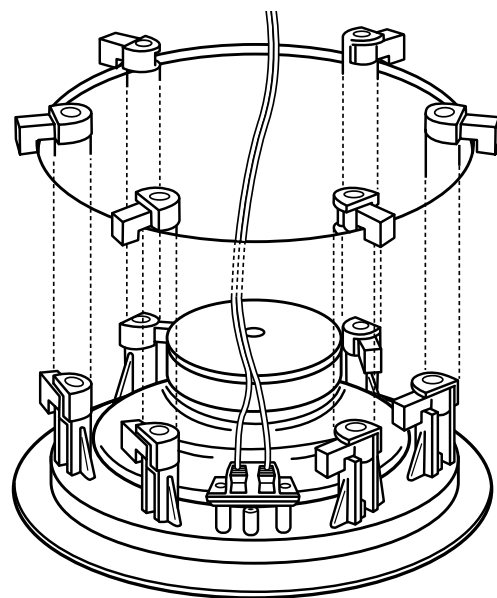
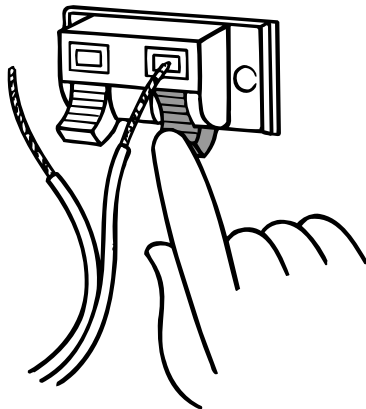

DRAWING 9

DRAWING 10



H

A SHORT TEST DRIVE

At this point, it's a good idea to test everything out.

Home Theater System

If you have connected your new B-I-C Ceiling Speakers to the rear "surround" output of your receiver, you will need to put your receiver in the "Pro-Logic" or "Digital" mode and use a source such as a DVD player or Hi-Fi VCR and suitably recorded movie to test your receiver surround operation.

Stereo Music System

1. Turn on your stereo system. Make sure that the **VOLUME** control is turned down and that the **BALANCE** control is set to center.
2. Activate a musical source such as FM, a tape, or CD player.
3. Gently turn up the volume. You should hear music coming out of your new B-I-C Ceiling Speakers! (If you don't, refer to the troubleshooting guide on the next page. We suggest you read the section on the next page titled "**Taking care of your new B-I-C Speakers**" (for further operating tips).

A QUICK TROUBLESHOOTING GUIDE

Before returning a B-I-C Ceiling Speaker for service, it's a good idea to check out these simple remedies first.

No sound from the speaker

1. Incorrect source selected on receiver or preamplifier.
2. Mute button pressed on receiver.
3. Wrong speaker output selected – many receivers have an “A” and “B” speaker switch. Make sure it's in the right position.
4. Unsecure connection at either the speaker or amplifier – double check them.
5. Balance control turned all the way left or right – return it to center.
6. Surround mode not turned on and/or surround level too low.
7. Bad connecting cable between sound source and amplifier – try a new cable.
8. Defective speaker – contact your B-I-C dealer or call 1-877-558-4242.

Intermittent sound from speaker or speaker plays initially but then shuts off.

1. Short circuit at either the amplifier or speaker connectors is activating the amp's protection circuits – double check connections, making sure no stray strands of wire from one conductor are touching the other.

Speakers plays but sound is mixed with hum

1. It could be a faulty patch cord. If so, there will be hum from your main speaker system as well as from your B-I-C Ceiling Speakers. Assuming you didn't have hum in your system before, one or both of the speaker wires has been run too close to internal AC house wiring. Re-route it so that it stays at least 2 feet away from AC power wiring when running parallel.

Speaker plays but sound is muffled and “strained.” Amplifier may shut off if volume is raised too far.

1. Too thin a gauge of wire has been run too far a distance between amp and speaker. Make sure that you have followed our suggestions as to wire gauge versus overall distance.

When volume is turned up to a high level, the treble cuts in and out.

1. The B-I-C Ceiling Speaker features a special protection circuit which electronically disconnects the tweeter if it starts getting too hot. Turn down your amplifier and make sure to read the section of this manual titled “Taking care of your new B-I-C speakers” which starts on this page.

FURTHER READING

TAKING CARE OF YOUR NEW B-I-C SPEAKERS

B-I-C Ceiling Speakers are designed to last the life of your home – if you follow a few simple rules.

The main “killers” of any loudspeaker system are 1) too little power at high volumes, 2) too much power at high volume, 3) transient thumps.

Not enough power

It's a surprising fact, but far more speakers are damaged by too little power than by too much! When an amplifier runs out of power while trying to re-create musical peaks, it causes a form of high frequency distortion called clipping. In moderate amounts, clipping simply makes the music sound terrible. In greater quantities over a period of time, it can damage or destroy the tweeters (high frequency reproduction speakers) in any speaker system. If you like your music LOUD, consider getting an amplifier with at least 60 watts per channel.

Too much power

There's nothing wrong with driving your B-I-C Speakers with a high power amp – the extra power helps them achieve quick musical transients found in digital recordings. However, you must remember to restrain yourself and not get too heavy-handed with the volume control (or remote buttons). If the music begins to sound distorted or you hear a “clacking” sound during bass notes, back off! And naturally, if the internal protection circuits are intermittently shutting off the tweeter, you're exceeding its safe power input level.

Transients

Loud, deep THUMPs, caused when you turn your stereo on or off, can seriously damage any loudspeaker including your B-I-C ceiling models. It's always a good practice to turn the volume down (or press the MUTE button if your receiver has one) when changing sources (such as changing from tuner to CD player input). Also remember to turn your system off before disconnecting any hook-up cables. When they're pulled out, a huge burst of low frequency hum often occurs if the system is still on.

Cleaning

B-I-C Ceiling Speakers are covered with a durable finish which can be cleaned with soap and water or spray cleaners. Avoid the use of ammonia-based cleaning products, however. If you've painted the grilles and frames, follow the paint manufacturer's cleaning instructions.

MORE ON AMPLIFIERS AND IMPEDANCE

Not all amplifiers or receivers can safely operate two sets of speakers at once. If you intend to use your B-I-C Ceiling Speakers at the same time as your main speakers –

or if you intend to hook up two sets of B-I-C Ceiling Speakers and use both at the same time, it's important to consider both the impedance of the speakers and the capabilities of the amplifier you're using.

First consult the owner's manual that came with the amp or receiver. It should tell you the minimum speaker impedances during simultaneous operation. On some models, the manual will recommend that only two pairs of 8 ohm speakers be used at the same time. Others might allow one set of 8-ohm speakers and one set of 4-ohm impedance speakers. A few extremely robust receivers and power amplifiers may even allow two sets of 4-ohm speakers.

If you can't readily determine this information, consult the dealer where you purchased the amplifier, or call the manufacturer.

Next, determine the impedance of your other speakers. It's often printed on the back of the enclosure down near the connection terminals, or you can consult the speaker's owners' manual.

B-I-C Ceiling Speakers are rated at 8 ohms impedance. In general, this means that most amplifiers will allow you to simultaneously operate one B-I-C Ceiling Speaker and one other set of 8-ohm loudspeakers – or two sets of B-I-C Ceiling Speakers.

If your other speakers are rated at 4 ohms, some amplifiers may experience difficulty driving both sets at once and shut off intermittently when the volume control is turned up.

In this case, you should operate only one set of speakers at a time or keep the volume extremely low.

INSTALLING B-I-C SPEAKERS DURING NEW CONSTRUCTION

Needless to say, installing speakers when a house is being built is far easier than doing it later.

- If possible run speaker wires after AC wiring is in place to avoid induced hum caused by close parallel proximity.
- Secure speaker wires in place along the run with insulated staples only and be careful not to pierce the insulation. Allow a bit of slack for expansion of building materials.
- Needless to say, the actual speakers should not be installed until the wall board is in place. In the meantime, leave several feet of wire coiled up and secured to the back side of the speaker opening.
- When it comes time to put up the drywall, make sure the speaker cutout hole doesn't extend farther than the sides of the mounting frame.
- After the wallboard is put up and finished, install the speakers as detailed on pages 5 - 6 of this manual.

B-I-C H-310C DESCRIPTIONS AND SPECIFICATIONS

The B-I-C H-310C in-ceiling speaker has been ruggedly constructed to withstand not only the extreme dynamic range found in today's digital sound sources, but also the rigors of temperature variation, dust and moisture encountered in permanent installation. Above all, they have been designed to give you the finest possible music reproduction possible in modest-sized speakers.

B-I-C Speakers Seven-Year Limited Warranty

If the B-I-C speaker system proves to be defective in materials or workmanship within seven years from the date of the original customer's purchase, we will at our option, repair or replace the defective product.

Limitation of Implied Warranties

Any implied warranties, including warranties of merchantability and fitness for a particular purpose, are limited in duration to the length of this warranty.

Disclaimer

THE WARRANTY STATED HEREIN IS IN LIEU OF ALL OTHER WARRANTIES, EXPRESS OR IMPLIED, INCLUDING MERCHANTABILITY AND FITNESS FOR PARTICULAR PURPOSE AND ALL OTHER LIABILITIES AND OBLIGATIONS OF B-I-C AMERICA, ALL OF WHICH ARE EXPRESSLY DISCLAIMED. B-I-C AMERICA HAS NOT MADE AND DOES NOT HEREBY MAKE ANY OTHER REPRESENTATION, WARRANTY OR COVENANT WITH RESPECT TO THE CONDITION, QUALITY, DURABILITY, DESIGN, OPERATION, CAPACITY, FITNESS FOR USE OR SUITABILITY OF THE B-I-C ELECTRONIC PRODUCT.

Exclusion of Certain Damages

B-I-C America's liability for any defective product is limited to repair or replacement of the product at our option. B-I-C shall not be liable for incidental or consequential damages of any kind or character because of product defects.

Some states do not allow limitation of how long an implied warranty lasts and/or do not allow the exclusion or limitation of incidental or consequential damages, so the above limitation and exclusions may not apply.

This Warranty Does Not Cover

Damage caused by abuse, accident, misuse, negligence, or improper operation (installation).

Products that have been altered or modified.

Any product whose serial number has been altered, defaced or removed.

Normal wear and maintenance.

Damages caused by shipping (All claims for shipping damages must be made with the carrier.)

Warranty Service

Warranty service must be performed by an authorized service center, usually a B-I-C dealer or its authorized agent. You may obtain a list of authorized service centers by calling 1-877-558-4242.

All warranty repairs must be accompanied by the original bill of sale. No other document is acceptable or required.

Specifications

H-310C

Frequency response 24Hz - 23kHz

Recommended amplifier power 10-250 watts per channel

Sensitivity 90dB

Woofers 10" Woven Fiber w/High Power Magnet

Midrange Pivoting 2 1/2" Woven Fiber

Tweeter Pivoting 1" titanium

Nominal Impedance 8 ohms

Overall Dimensions 13 1/2" dia.

Required cutout 12 1/2" dia.

Required depth 5 1/4"

Due to our continual efforts to improve product quality as new technology and techniques become available, B-I-C America reserves the right to revise speaker systems specifications without notice.



B-I-C America
925 N. Shepard Street
Anaheim, CA 92806
www.bicamerica.com

Tech Support: 1-877-558-4242 (4BIC)